

Oxidation of Acetylated Guanosine by 3,3-Disubstituted 1,2-Dioxetanes through Nucleophilic Attack on the Peroxide Bond: Model Studies on the Oxidative DNA Damage by Reactive Peroxides

Waldemar Adam* and Alexander Treiber

Contribution from the Institute of Organic Chemistry, University of Würzburg, Am Hubland, D-97074 Würzburg, Germany

Received July 8, 1994[®]

Abstract: The reaction of the disubstituted 3-(methoxymethyl)-3-phenyl-1,2-dioxetane (**1a**) with the acetylated guanine nucleoside (**2**) in methanol affords 8-methoxyguanosine **5** as oxidation product, as well as guanine (**6**) and 1-methoxyribose **7** by deglycosylation (total yield ca. 30%). The dioxetane-derived reduction product constitutes the 1,2-diol **4a**, while the major dioxetane-derived product (85%) is ω -methoxyacetophenone (**3a**). A Grob-type fragmentation is made responsible for the exclusive formation of the dioxetane cleavage products in the reactions with the acetylated nucleosides **8–10** derived from adenine, cytosine, and thymine. Rather than redox chemistry, this guanosine oxidation, unprecedented for peroxides, is proposed to involve nucleophilic attack by the N-7 atom of the nucleosides on the peroxide bond of the dioxetane **1a** electrophile to generate a zwitterionic intermediate. S_N2 attack by methanol at the C-8 position of the guanine moiety in the zwitterionic intermediate leads to the 8-methoxyguanosine **5** and the diol **4a**. Alternatively, heterolytic cleavage of the glycosidic bond affords the methoxylated ribose **7** (after methanol trapping) and the N-7-alkoxylated guanine. The latter, after protonation, subsequently undergoes Grob fragmentation into guanine (**6**) and the dioxetane decomposition products ω -methoxyacetophenone (**3a**) and formaldehyde. We propose that the present novel oxidation of guanosine is general for electrophilic peroxides and may constitute a prominent route of oxidative DNA damage. In contrast, the corresponding 3-(bromomethyl)-3-phenyl-1,2-dioxetane (**1b**) gave with the guanosine **2** an intractable, complex product mixture, for which presumably the bromo substituent is responsible on account of competitive alkylation chemistry. However, with the 2'-deoxythymidine **10**, a novel acid-catalyzed ring-opening of the bromo-substituted dioxetane **1b** to its β -methoxy hydroperoxide **11b** is observed, a reaction which does not take place for the methoxy-substituted dioxetane **1a**. This unusual process for simple dioxetanes is rationalized in terms of stabilization of the intermediary benzylic cation by the adjacent β -bromo substituent through neighboring group participation.

Introduction

1,2-Dioxetanes have been postulated as unstable intermediates in a variety of biologically relevant oxidation processes.¹ For example, in the metabolism of arenes and heteroarenes to the corresponding *cis*-diols by the bacterium *Pseudomonas putida*, 1,2-dioxetanes have been proposed as labile intermediates.² The fact that the enzymatic oxidation of 7,8-dihydroxy-7,8-dihydrobenzo[*a*]pyrene proceeds under emission of light also hints at the intermediacy of 1,2-dioxetanes.³

In our investigations on the genotoxic effects of these reactive cyclic peroxides, we have demonstrated that 1,2-dioxetanes induce a variety of DNA lesions.⁴ Besides the formation of pyrimidine dimers,⁵ by means of the FPG protein (formamidopyrimidine-DNA-glycosylase), we have shown that the majority of DNA lesions constitute oxidation to 7,8-dihydro-8-oxoguanine (8-oxoGua) and formamidopyrimidine (Fapy).⁶

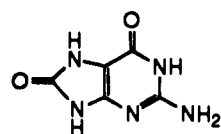

7,8-dihydro-8-oxoguanine

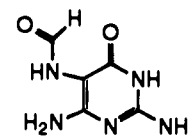

guanine-Fapy

Recently, we have reported that 3,3-disubstituted 1,2-dioxetanes readily undergo nucleophilic substitution reactions at the peroxide bond with a wide variety of nucleophiles.⁷ For example, secondary amines have been shown to form persistent hydroxylamino ethers with 1,2-dioxetanes, while the addition products with tertiary amines are extremely sensitive toward hydrolysis (Scheme 1).⁸

Since the DNA bases are polyfunctional nitrogen heterocycles, with the propensity to serve as reactive nucleophiles, e.g. their alkylation in DNA, it was of interest to investigate the reactions of the nucleosides with the electrophilic 3,3-disubstituted 1,2-dioxetanes. This should provide mechanistic insight into the oxidative DNA damage by these strained

[®] Abstract published in *Advance ACS Abstracts*, February 15, 1995.

(1) Cilento, G.; Adam, W. *Photochem. Photobiol.* **1988**, *43*, 361–369.

(2) (a) Gibson, D. T.; Cardini, G. E.; Maseles, F. C.; Kallio, R. E. *Biochemistry* **1978**, *17*, 1631–1635. (b) Boyd, D. R.; Sharma, N. D.; Austin, R.; McMordie, S.; Chima, J.; Dalton, D. *Tetrahedron Lett.* **1992**, *33*, 1241–1244.

(3) Thompson, A.; Biggley, W. H.; Posner, G. H.; Lever, J. R.; Seliger, H. H. *Biochim. Biophys. Acta* **1986**, *882*, 210–219.

(4) Adam, W.; Beinhauer, A.; Mosandl, T.; Saha-Möller, C. R.; Vargas, F.; Epe, B.; Müller, E.; Schiffmann, D.; Wild, D. *Environ. Health Perspect.* **1990**, *88*, 89–97.

(5) (a) Lamola, A. A. *Biochem. Biophys. Res. Commun.* **1971**, *43*, 898–899. (b) Adam, W.; Beinhauer, A.; Epe, B.; Fuchs, R.; Griebbeck, A.; Hauer, H.; Mützel, P.; Nassi, L.; Schiffmann, D.; Wild, D. In *Primary Changes and Control Factors in Carcinogenesis*; Friedberg, T., Oesch, F., Eds.; Deutscher Fachschriften Verlag: Wiesbaden, Germany, 1986; pp 64–67.

(6) Epe, B.; Müller, E.; Adam, W.; Saha-Möller, C. R. *Chem.-Biol. Interact.* **1992**, *85*, 265–281.

Scheme 1

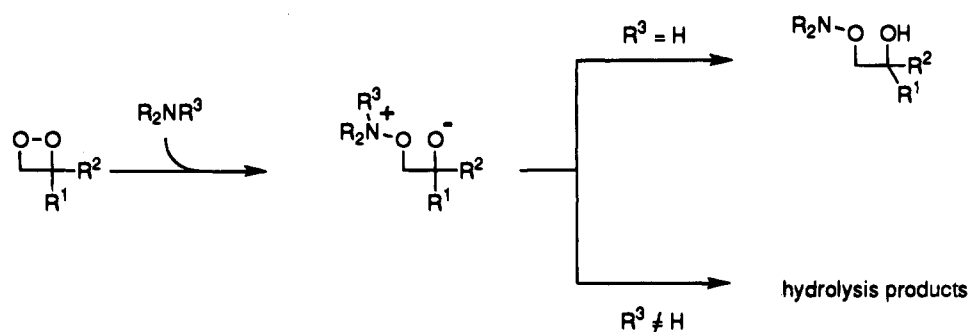

Scheme 2

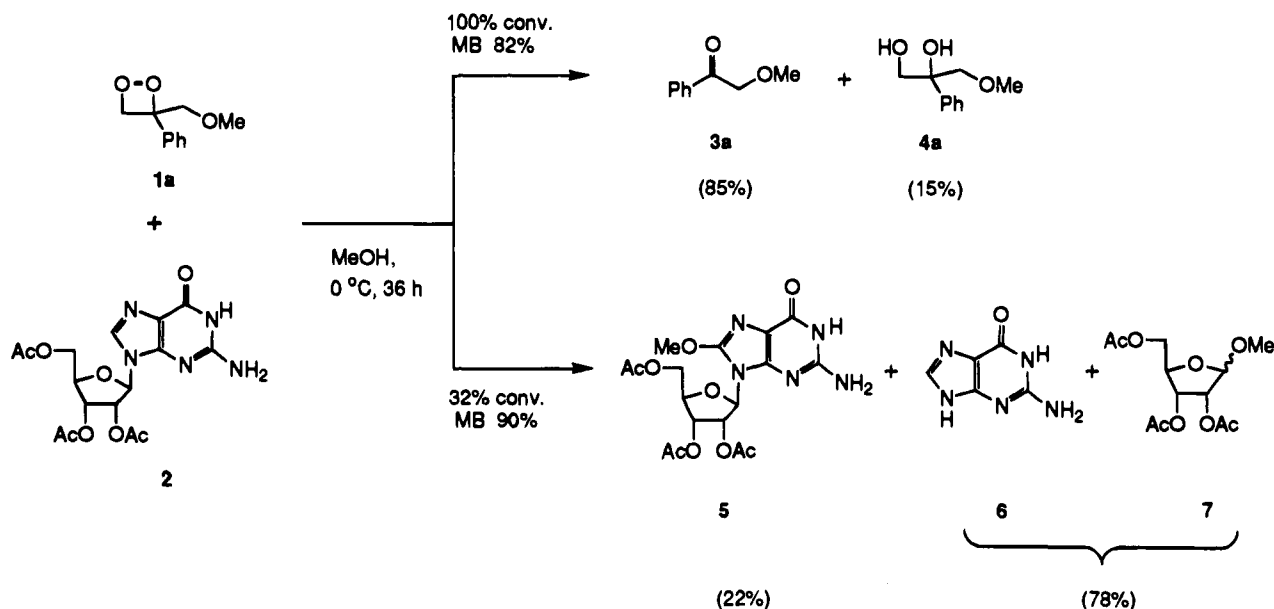

peroxides as a consequence of nucleophilic substitution by the nucleosides on the dioxetane oxygen–oxygen bond. For this purpose, we employed the acetylated nucleosides of guanine, adenine, cytosine, and thymine.

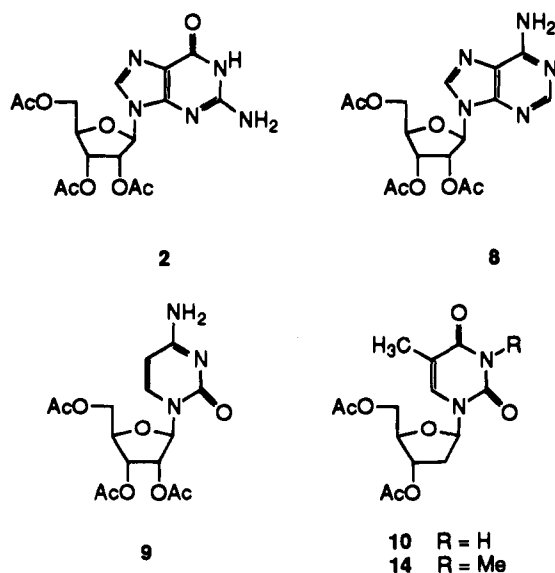

Our results reveal that, of the four DNA bases, only guanine is prone to electrophilic oxidation by 1,2-dioxetanes; the others catalyze the decomposition of these labile peroxides.

Results

For our model studies on the oxidative damage of DNA bases by 1,2-dioxetanes, the unknown 3-(methoxymethyl)-3-phenyl-dioxetane (**1a**) and 3-(bromomethyl)-3-phenyldioxetane (**1b**)⁹ were used. Dioxetane **1a** was obtained in an overall yield of 22% according to the Kopecky method¹⁰ by starting from 3-methoxy-2-phenylpropene,¹¹ with the corresponding β -bromo hydroperoxide as intermediate product.

The transformations of the dioxetane **1a** with the acetylated nucleosides were carried out in methanol at 0 °C, and the consumption of the dioxetane **1a** was monitored by the peroxide test (KI/HOAc). When dioxetane **1a** was allowed to react with 1 equiv of triacetylguanosine (**2**) for 36 h, a mixture of five products (Scheme 2) was obtained, which were identified by means of reversed-phase HPLC and co-injection with the independently synthesized authentic materials.

Thus, after complete consumption (100%) of the dioxetane **1a**, the triacetylguanosine (**2**) was converted to the extent of 32% to afford 85% of ω -methoxyacetophenone (**3a**) and 15% of 3-methoxy-2-phenylpropane-1,2-diol (**4a**) as dioxetane **1a**

(7) Adam, W.; Heil, M.; Mosandl, T.; Saha-Möller, C. R. In *Organic Peroxides*; Ando, W., Ed.; John Wiley & Sons: Chichester, U.K., 1992; pp 221–254.

(8) Adam, W.; Heil, M. *J. Am. Chem. Soc.* **1992**, *114*, 5591–5598.

(9) Adam, W.; Heil, M. *Chem. Ber.* **1992**, *125*, 235–241.

(10) Kopecky, K. R.; Filby, J. E.; Mumford, C.; Lockwood, P. A. *Can. J. Chem.* **1975**, *53*, 1102–1122.

(11) Baldwin, M. G.; Reed, S. F., Jr. *J. Polym. Sci., Part A-1* **1968**, *6*, 2627–2635.

Scheme 3

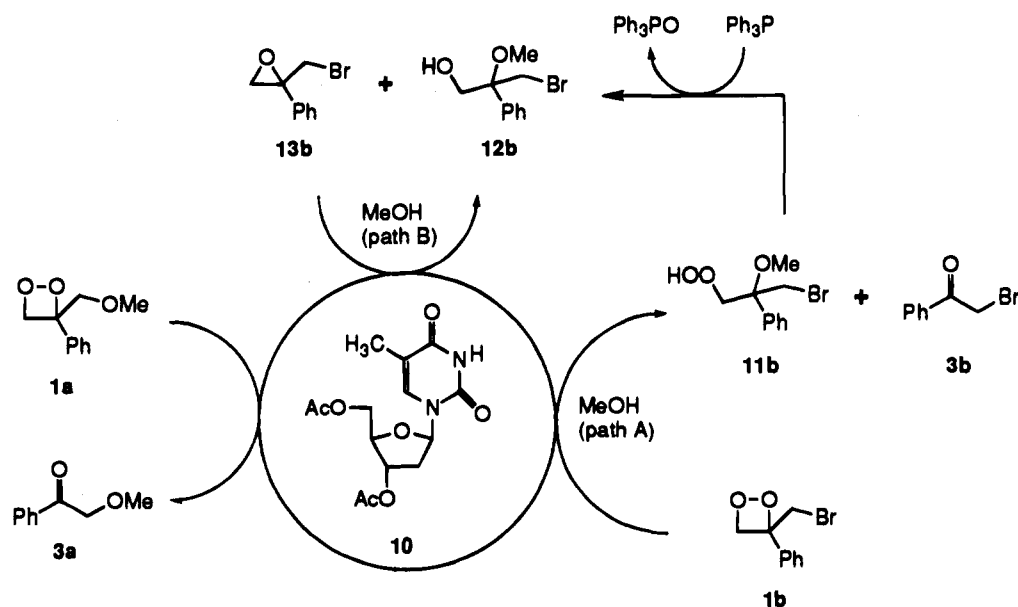

products (relative yields normalized to 100%, which are based on complete consumption of the dioxetane **1a**), and 22% of 2',3',5'-triacetyl-8-methoxyguanosine (**5**) and 78% of guanine (**6**) as guanosine **2** products [relative yields normalized to 100%, which are based on 32% consumption of nucleoside **2**; for the latter, the corresponding amount (78%) of 2,3,5-triacetyl-1-methoxyribose (**7**) was isolated]. The mass balance (MB) was 82% for the dioxetane **1a** and 90% for the nucleoside **2**.

The unknown diol **4a** was prepared in 53% yield by dihydroxylation of 3-methoxy-2-phenylpropene with H₂O₂/formic acid. The 2',3',5'-triacetyl-8-methoxyguanosine (**5**) was made from 8-bromoguanosine by methoxylation in the C-8 position,¹² followed by acetylation with acetic anhydride/triethylamine in acetonitrile and *p*-(dimethylamino)pyridine as catalyst.¹³ The 2,3,5-triacetyl-1-methoxyribose (**7**) was synthesized according to the literature procedure,¹⁴ while ω-methoxyacetophenone (**3a**) and guanine (**6**) were commercially available.

The formation of guanine (**6**) and 1-methoxyribose **7** constitutes a formal hydrolysis of the guanosine **2** in methanol. However, this process normally requires acid catalysis. Its origin may be a Cannizzarro-type disproportionation of the dioxetane cleavage product formaldehyde into formic acid and methanol. However, a control experiment with guanosine **2** and formic acid (0.35 equiv, the maximum theoretical amount possibly formed in the dioxetane reaction) under the same conditions of the dioxetane reaction afforded no deglycosylation. This is in accordance with literature,¹⁵ which demands high concentrations of acid and elevated temperatures for deglycosylation and suggests the direct intervention of the dioxetane **1a** in the deglycosylation process of the acetylated nucleoside **2**.

When 3-(bromomethyl)-3-phenyldioxetane (**1b**) was allowed to react with guanosine **2**, an intractable, highly complex product mixture was formed, presumably due to secondary alkylation reactions of the dioxetane decomposition product, namely ω-bromoacetophenone (**3b**), with the guanosine **2** and the

guanosine-derived products. In view of these complications, further work with the bromodioxetane **1b** was abandoned. Nonetheless, the formation of acetophenone, the debrominated dioxetane fragmentation product, was rigorously ruled out.

The reaction of 3-(methoxymethyl)-3-phenyldioxetane (**1a**) with 1 equiv of 2',3',5'-triacetyladenosine (**8**) at 0 °C for 3 d decomposed the dioxetane to ω-methoxyacetophenone (**3a**), as observed by NMR spectroscopy. Similar results were obtained in the transformations of dioxetane **1a** with 2',3',5'-triacetylcytidine (**9**) and 3',5'-diacetyl-2'-deoxythymidine (**10**). The reaction times for complete consumption of dioxetane **1a** were determined iodometrically to be 35 h for cytidine **9** and 36 h for 2'-deoxythymidine **10**.

As a control experiment, the rate of thermal decomposition of dioxetane **1a** under the reaction conditions was determined. For this purpose, a sample of **1a** in deuterated methanol was stored at 0 °C and the decomposition rate assessed by ¹H NMR spectroscopy with hexamethyldisiloxane as internal standard. Within 24 h, about 15–20% of dioxetane **1a** was decomposed under these conditions.

In contrast to dioxetane **1a**, the reaction of 3-(bromomethyl)-3-phenyldioxetane (**1b**) with 2'-deoxythymidine **10** afforded a 55:45 mixture of ω-bromoacetophenone (**3b**) and 1-(bromomethyl)-1-methoxy-1-phenylethyl hydroperoxide (**11b**) after 4 d reaction time (path A, Scheme 3). The hydroperoxide **11b** was characterized by ¹H and ¹³C NMR spectroscopy, but it decomposed on attempted isolation by low-temperature column chromatography. Subsequent deoxygenation with triphenylphosphine led to the alcohol **12b** which was isolated and fully characterized. When 2'-deoxythymidine **10** was allowed to react with 1 equiv of 2-(bromomethyl)-2-phenyloxirane (**13b**) in methanol for 48 h at room temperature, the quantitative formation of alcohol **12b** was observed by ¹H and ¹³C NMR spectroscopy (path B, Scheme 3). In a control experiment, it was demonstrated that the epoxide **13b** is persistent toward methanol in the absence of 2'-deoxythymidine **10**.

Additionally, the *N*-3-methyl-2'-deoxythymidine **14** was prepared in 91% yield by reaction of 2'-deoxythymidine **10** with a small excess of diazomethane for 14 h at 0 °C. When nucleoside **14** was treated with the dioxetanes **1a,b** in methanol at 0 °C, only slow decomposition to the known ω-substituted acetophenones **3a,b** was observed by NMR spectroscopy.

(12) Ikehara, H.; Muneyama, K. *Chem. Pharm. Bull.* **1966**, *14*, 46–49.

(13) Matsuda, A.; Shinozaki, M.; Suzuki, M.; Watanabe, K.; Miyasaka, T. *Synthesis* **1986**, 385–386.

(14) Guthrie, R. D.; Smith, S. C. *Chem. Ind. (London)* **1968**, 547–548.

(15) Teoule, R.; Boncel, A.; Bert, C.; Fouque, B. *J. Am. Chem. Soc.* **1978**, *100*, 6749–6752.

Discussion

The reaction of dioxetane **1a** with the acetylated guanosine **2** consists of two independent processes. While the formation of 8-methoxyguanosine **5** and diol **4a** constitutes a redox reaction, guanine (**6**) and the methylated ribose **7** are the result of guanosine **2** methanolysis.

The molecular mechanism of the oxidative DNA damage by 1,2-dioxetanes usually involves excited carbonyl products formed through thermolysis, which may subsequently induce one-electron oxidations¹⁶ as well as energy transfer to molecular oxygen¹⁷ to generate singlet oxygen. However, since all experiments were performed at low temperatures, the efficient formation of excited carbonyl products by dioxetane thermolysis can certainly be ruled out. Moreover, the direct electron transfer from the guanosine **2** to the dioxetanes **1** has been shown to be unlikely through the use of the bromo derivative **1b**. Since electron transfer to the dioxetane **1b** results in its radical anion, fragmentation leads to formaldehyde and the ketyl radical anion of ω -bromoacetophenone. The latter is known to undergo rapid loss of a bromide ion and abstraction of a hydrogen atom from the solvent to afford acetophenone.¹⁸ Thus, the absence of acetophenone as the debrominated dioxetane fragmentation product speaks against the involvement of electron transfer processes.

In view of the propensity of guanosine to react with electrophiles at the N-7 position¹⁹ and the fact that 1,2-dioxetanes are readily attacked at the peroxide bond by amines (Scheme 1),⁸ we rationalize the present guanosine oxidation (Scheme 2) in terms of the mechanism in Scheme 4. Thus, nucleophilic attack by the N-7 position of the guanosine **2** on the peroxide bond of the dioxetane **1a** generates first the zwitterionic intermediate **A**. In contrast to the reactions of 1,2-dioxetanes with aliphatic amines, the resulting dipolar adduct is too labile for isolation or even spectral characterization. Its labile nature derives from activation of the C-8 position in the guanine toward nucleophilic attack. Consequently, methanol adds at the activated C-8 position to afford 8-methoxyguanosine **5**, while the dioxetane fragment is released as the diol **4a** (path A, Scheme 4).

This mechanistic rationalization for the formation of 8-methoxyguanosine **5** is supported by a recent paper on the formation of 9-benzyl-7,8-dihydro-8-oxoguanosine from the 9-benzyl-7-methoxyguanosine by the action of aqueous base²⁰ (Scheme 5). A similar situation applies in the reaction of guanosine **2** with an excess of hydroxyamine-*O*-sulfonic acid at pH 2–4,^{19a} which leads to 8-aminoguanosine (Scheme 6). The first step involves electrophilic N-7 amination, which is followed by nucleophilic C-8 hydroxyamination of the 7-aminoguanosine by NH₂OH (from hydrolysis of the hydroxyamino sulfonic ester) and elimination of the 7-amino group. Finally, the 8-(hydroxyamino)guanosine is reduced to the 8-aminoguanosine by another equivalent of NH₂OH.

Path B in Scheme 4 describes the deglycosylation of the dipolar intermediate **A**. The resulting cation of the ribose is trapped by methanol to yield 1-methoxyribose **7** (path C) and the guanine-*N*-7-alkoxide **B** intermediate. The latter may directly undergo Grob fragmentation²¹ to give guanine (**6**) after protonation and the dioxetane cleavage products, namely ω -methoxyacetophenone (**3a**) and formaldehyde. Alternatively, the intermediate **B** may first be protonated (path D) to the dipolar structure **C**, which subsequently suffers Grob fragmentation as illustrated in the mesomeric structure **C'**. Such fragmentations are well-known for amine adducts of peroxides.²²

The present results on the oxidation of guanosine **2** through nucleophilic attack on the peroxide bond of the dioxetane **1a** constitute an important model study for the formation of 7,8-dihydro-8-oxoguanosine in cellular as well as in isolated DNA,²³ not only for the energy-rich 1,2-dioxetanes but for reactive peroxides in general. The DNA-bound guanine is activated at the C-8 position for nucleophilic substitution by N-7 attack on the peroxide bond to afford the oxidation products, of which, in aqueous media, the 7,8-dihydro-8-oxoguanine is the most prominent. Worthy of emphasis, however, is that the oxidized guanosine does not arise from redox chemistry but rather from S_N2-type reactions with the peroxide. Moreover, it should be noted that in contrast to singlet oxygen,²⁴ the incorporated oxygen in the C-8 position of the guanine does not derive from the oxidant but from the solvent methanol.

The formation of hydroperoxide **5b** in the reaction of dioxetane **1b** with 2'-deoxythymidine **10** is unusual because such transformations have not been documented for simple alkyl-substituted dioxetanes. It can be rationalized by acid-catalyzed ring-opening of the dioxetane and subsequent trapping of the benzylic cation by methanol (path A, Scheme 3). Relevant examples for the present study are the benzofuran dioxetanes, which have been converted to the corresponding methoxy hydroperoxides when treated with catalytic amounts of acid in the presence of methanol.²⁵ The propensity of 2'-deoxythymidine **10** (pK_A 9.9²⁶) for acid catalysis is further demonstrated by the fact that it also promotes the ring-opening of epoxide **13b** to the alcohol **12b** (path B, Scheme 3), as confirmed through a control experiment. Furthermore, for 3-methyl-2'-deoxythymidine **14**, which cannot act as an acid catalyst, the formation of the hydroperoxide **11b** is completely suppressed. This finding strongly supports the mechanistic rationalization in Scheme 3.

The difference in the reactivity between 3-methoxy- and 3-(bromomethyl)-substituted dioxetane **1a** and **1b** in the reaction with 2'-deoxythymidine **10** demands an explanation since the methoxy derivative **1a** does not undergo acid-catalyzed ring-opening to the hydroperoxide **11a**. The additional stabilization of the intermediary benzylic cation by the adjacent β -bromo substituent may derive from the formation of the bromonium cation²⁷ (Scheme 7), which is then trapped by methanol in the form of the hydroperoxide **11b**. Such stabilization is expectedly

(16) Kochevar, I. E.; Dunn, D. A. In *Bioinorganic Chemistry*; Morrison, H., Ed.; John Wiley & Sons: New York, 1990; Vol. 1, pp 273–316.

(17) (a) Epe, B. *Chem.-Biol. Interact.* **1991**, *80*, 239–260. (b) Piette, J. *J. Photochem. Photobiol. Part B* **1991**, *11*, 241–260.

(18) (a) Tanner, D. D.; Chen, J. J.; Chen, L.; Luelo, C. *J. Am. Chem. Soc.* **1991**, *113*, 8074–8081. (b) Adam, W.; Heil, M.; Hutterer, R. *J. Org. Chem.* **1992**, *57*, 4491–4495.

(19) (a) Kohda, K.; Baba, K.; Kawazoe, Y. *Tetrahedron* **1990**, *46*, 1531–1540. (b) Bartsch, H.; Malaveille, C.; Barbin, A.; Planche, G. *Arch. Toxicol.* **1971**, *41*, 349–351. (c) Druckrey, H.; Kruse, H.; Preussmann, R.; Ivankovic, S.; Landschütz, C. *Z. Krebsforsch.* **1970**, *74*, 241–270. For a review, see: Singer, B.; Grunberger, D. In *Molecular Biology of Mutagens and Carcinogens*; Plenum Press: New York, 1983; pp 45–96.

(20) Werbonetz, K. A.; Macdonald, T. L. *Bioorg. Med. Chem. Lett.* **1994**, *4*, 2323–2326.

(21) Grob, C. A. *Angew. Chem., Int. Ed. Engl.* **1969**, *8*, 535–546.

(22) (a) Huisgen, R.; Kolbeck, W. *Tetrahedron Lett.* **1965**, 783–787.

(b) Srivasan, S.; Taylor, K. G. *J. Org. Chem.* **1990**, *55*, 1779–1786.

(23) Adam, W.; Ahrweiler, M.; Saha-Möller, C.; Sauter, M.; Schönberger, A.; Epe, B.; Müller, E.; Schiffmann, D.; Stopper, H.; Wild, D. *Toxicol. Lett.* **1993**, *67*, 41–55.

(24) Buchko, G. W.; Cadet, J.; Berger, M.; Ravanat, J. L. *Nucleic Acids Res.* **1992**, *20*, 4847–4851.

(25) Adam, W.; Hadjarapoglou, L.; Mosandl, T.; Saha-Möller, C. R.; Wild, D. *J. Am. Chem. Soc.* **1991**, *113*, 8005–8011.

(26) Shugar, D.; Fox, J. J. *Biochim. Biophys. Acta* **1952**, *9*, 199–206.

(27) Winstein, S.; Lucas, H. J. *J. Am. Chem. Soc.* **1939**, *61*, 1576–1581, 2845–2848.

Scheme 4

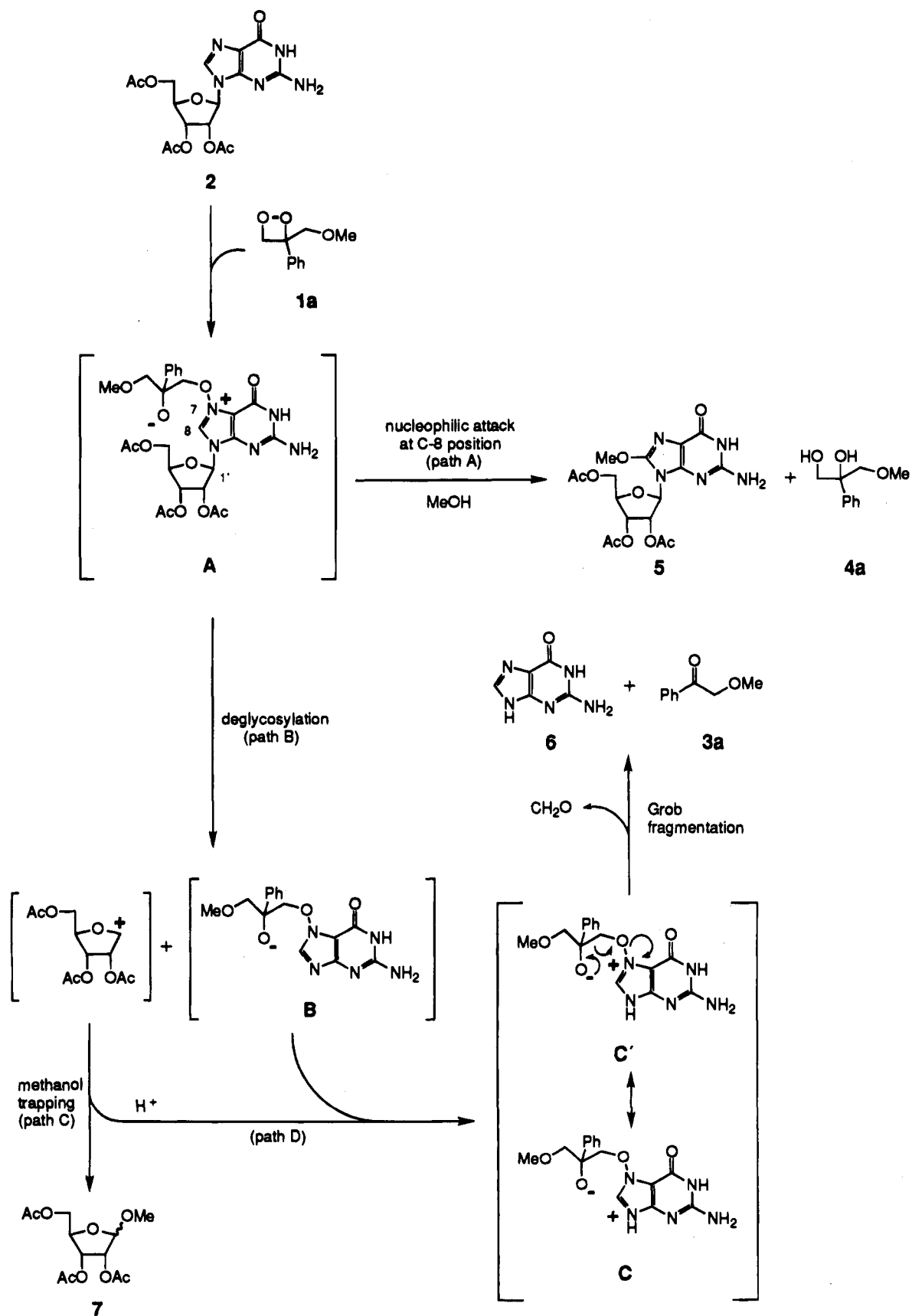

less effective for the adjacent β -methoxy substituent in the dioxetane **1a**.

In summary, we have seen that guanine is the only DNA base which affords oxidation-type products with the dioxetane **1a**; the other bases adenine, cytosine, and thymine catalyze the

fragmentation of the dioxetane **1a** into ω -methoxyacetophenone (**3a**) and formaldehyde. Rather than redox chemistry,²⁸ the oxidation derives from nucleophilic attack of the N-7 atom in

(28) (a) Steenken, S. *Chem. Rev.* **1989**, *89*, 503–520. (b) Symons, M. C. R. *J. Chem. Soc., Faraday Trans. 1* **1987**, *83*, 1–12.

Scheme 5

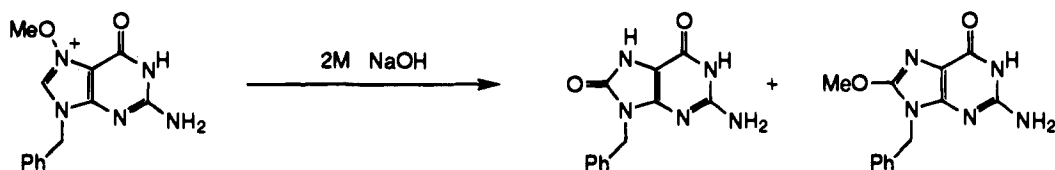

Scheme 6

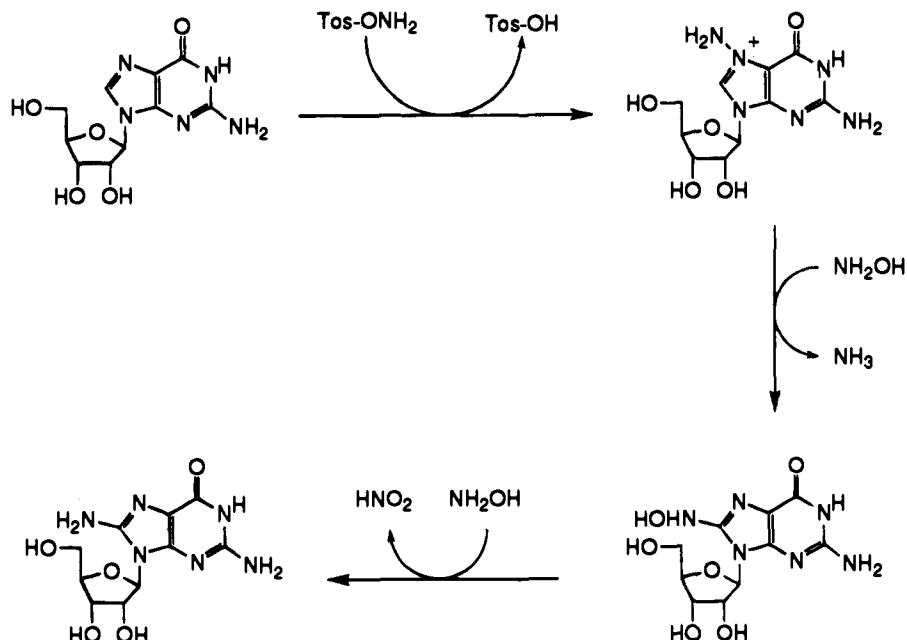

Scheme 7

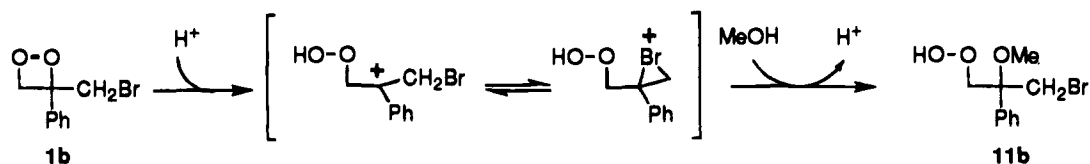

the guanosine on the peroxide bond of the dioxetane **1a** (Scheme 4). The resulting zwitterionic intermediate **A** is activated at the C-8 position of the guanine moiety toward nucleophilic attack by MeOH to yield 2',3',5'-triacetyl-8-methoxyguanosine (**5**) and diol **4a**. In competition, guanine (**6**) arises from Grob fragmentation of the deglycosylated N-7 alkoxy-substituted guanine intermediate **B**, activated through its protonated form C/C' (Scheme 4). We suspect that this hitherto unprecedented oxidation of DNA is quite general for peroxides.

Experimental Section

General Aspects. Melting points were taken on a Reichert Thermovar Kofler apparatus and are uncorrected. ^1H NMR spectra were measured with Bruker AC 200 (200 MHz) and Bruker AC 250 (250 MHz) spectrometers with TMS as internal standard. ^{13}C NMR spectra were measured with Bruker AC 200 (50 MHz) and Bruker AC 250 (63 MHz) spectrometers with CDCl_3 and $\text{DMSO}-d_6$ as internal standards. If not otherwise stated, all NMR spectra were recorded at room temperature. Infrared spectra were measured with a Perkin-Elmer 1420 ratio recording infrared spectrophotometer. Combustion analyses were carried out by the Microanalytical Division of the Institute of Inorganic Chemistry, University of Würzburg. Column chromatography was carried out on silica gel (63–200 μm) from Woelm and neutral alumina from ICN Biomedicals with an adsorbant/substrate ratio of ca. 100:1. Thin layer chromatography (TLC) was carried out on Polygram SIL G/UV $_{254}$ (40 \times 80 mm) from Macherey-Nagel; the peroxides were detected by 10% aqueous KI solution, and other

products were detected either by a 254 nm UV lamp or by means of a 5% ethanolic solution of molybdophosphoric acid.

The dioxetane **1b** and the acetylated guanosine **2**,¹³ adenosine **8**,²⁹ cytidine **9**,³⁰ and 2'-deoxythymidine **10**³¹ were synthesized according to literature procedures.

Caution! Even though we have not experienced any problems, the β -bromo hydroperoxide and the 1,2-dioxetanes **1** may decompose spontaneously when allowed to warm up above 0 $^\circ\text{C}$. Especially the dioxetanes **1** must be handled with care by applying all safety measures since they may detonate even at lower temperatures.

1-Bromo-2-hydroperoxy-2-phenyl-3-methoxypropane. A sample of 1.60 g (10.8 mmol) of 3-methoxy-2-phenylpropene was dissolved in 20 mL of diethyl ether and the solution cooled to 0 $^\circ\text{C}$. After addition of 2.2 mL of 85% hydrogen peroxide, the solution was cooled to -35 $^\circ\text{C}$ and 1.54 g (5.40 mmol) of 1,3-dibromo-4,4-dimethylthioin was added in small portions over a period of 1.5 h. The reaction mixture was stirred for 2 h at -35 $^\circ\text{C}$ and another 2 h at 0 $^\circ\text{C}$, the phases were separated, and the organic layer was washed twice with ice-cold, saturated solutions of NaHCO_3 , $(\text{NH}_4)_2\text{SO}_4$, and NaCl (each 25 mL). After drying over MgSO_4 at 0 $^\circ\text{C}$, the solvent was evaporated at 0 $^\circ\text{C}/15$ Torr to afford a colorless oil. Purification by low-temperature silica gel column chromatography (-20 $^\circ\text{C}$) with methylene chloride as eluent gave 1.72 g (61%) of the β -bromo hydroperoxide as a colorless oil: R_f (methylene chloride) 0.26; IR (CCl_4) ν 3780–3660, 3180, 3080,

(29) Bredereck, H. *Chem. Ber.* **1947**, *80*, 401–405.

(30) Beránek, J.; Drasar, P. *Collect. Czech. Chem. Commun.* **1977**, *42*, 366–369.

(31) Michelson, A. M.; Todd, A. R. *J. Chem. Soc.* **1955**, 816–823.

3000, 2920, 1800, 1650, 1570, 1480, 1390, 1270, 1220, 1170, 1100 cm^{-1} ; ^1H NMR (CDCl_3 , 200 MHz, -20°C) δ 3.42 (s, 3H), 3.83–4.02 (m, 4H), 7.35–7.65 (m, 5H), 9.38 (s, 1H); ^{13}C NMR (CDCl_3 , 50 MHz, -20°C) δ 34.5 (t), 59.6 (q), 73.1 (t), 85.1 (s), 125.9 (d), 128.3 (d), 128.3 (d), 137.8 (s). Anal. Calcd for $\text{C}_{10}\text{H}_{13}\text{BrO}_3$ (261.1): C, 45.99; H, 5.03. Found: C, 46.01; H, 5.13.

3-(Methoxymethyl)-3-phenyldioxetane (1a). A mixture of 700 mg (17.5 mmol) of NaOH in 10 mL of water and 15 mL of methylene chloride was cooled to 0°C , and a solution of 1.20 g (4.60 mmol) of β -bromo hydroperoxide in 5 mL of methylene chloride was slowly added within 10 min. After the reaction mixture was vigorously stirred for 2.5 h, the phases were separated, the organic layer was washed twice with 10 mL of an ice-cold, saturated solution of NaCl and dried over MgSO_4 for 10 min at 0°C , and the solvent was evaporated at $0^\circ\text{C}/15$ Torr. The crude product mixture was purified by low-temperature column chromatography [neutral alumina, activity III, 1:1 methylene chloride/petroleum ether (30 – 50°C), -20°C] to yield 298 mg (36%) of dioxetane **1a** as a yellow oil: R_f (1:1 methylene chloride/petroleum ether) 0.54; IR (CCl_4) ν 3190, 3000, 2930, 2910, 1810, 1710, 1650, 1570, 1400, 1390, 1270, 1225, 1205, 1100 cm^{-1} ; ^1H NMR (CDCl_3 , 200 MHz, -20°C) δ 3.57 (s, 3H), AB pattern ($\delta_A = 3.71$, $\delta_B = 3.82$, $J = 11.9$ Hz, 2H), AB pattern ($\delta_A = 5.29$, $\delta_B = 5.69$, $J = 4.2$ Hz, 2H), 7.30–7.60 (m, 5H); ^{13}C NMR (CDCl_3 , 50 MHz, -20°C) δ 59.8 (q), 75.7 (t), 78.2 (t), 88.3 (s), 124.2 (d), 128.3 (d), 128.5 (d), 139.6 (s). Anal. Calcd for $\text{C}_{10}\text{H}_{12}\text{O}_3$ (180.2): C, 66.64; H, 6.73. Found: C, 66.71; H, 6.84.

Reaction of 3-(Methoxymethyl)-3-phenyldioxetane (1a) with 2',3',5'-Triacetylguanosine (2). A solution of 150 mg (0.366 mmol) of the guanosine **2** in 30 mL of dry methanol was cooled to 0°C , and 66.0 mg (0.366 mmol) of dioxetane **1a** was added. The solution was stirred for 36 h until the negative peroxide test (KI/HOAc) indicated the complete conversion of the dioxetane. The crude product mixture was submitted to isocratic, reversed-phase HPLC (C_{18} column, 85:15 water/methanol mixture, at 2 mL/min flow rate) and 38.4 mg (70%) of ω -methoxyacetophenone (**3a**) and 8.0 mg (12%) of 3-methoxy-2-phenylpropane-1,2-diol (**4a**). While 68% of unconverted triacetylguanosine (**2**) was reisolated, an additional 10.9 mg (22%) of 2',3',5'-triacetyl-8-methoxyguanosine (**8**), 14.4 mg of guanine (**6**), and 25.5 mg of 2,3,5-triacetyl-1-methoxyribofuranose (**7**) were found, which sum up to 78% yield based on 32% consumption of the guanosine **2**. The unknown diol **4a** and the 2',3',5'-triacetyl-8-methoxyguanosine (**5**) were synthesized as described below, while 2,3,5-triacetyl-1-methoxyribofuranose (**7**) was prepared according to the literature procedure. ω -Methoxyacetophenone (**3a**) and guanine (**6**) were commercially available.

3-Methoxy-2-phenylpropane-1,2-diol (4a). In 15 mL of chloroform were dissolved 1.50 g (10.1 mmol) of 3-methoxy-2-phenylpropene¹¹ and 1.7 mL (15.2 mmol) of 35% hydrogen peroxide; 7 mL of formic acid was added, and the mixture was stirred for 15 h at room temperature. All volatile components were removed at $40^\circ\text{C}/15$ Torr, to the residue were added 20.0 mg of *p*-toluenesulfonic acid and 20 mL of methanol, and the mixture was refluxed for 2 h. After evaporation of the solvent at $20^\circ\text{C}/15$ Torr, the remainder was taken up in 50 mL of methylene chloride and the solution was washed twice each with 20 mL of saturated solutions of NaHCO_3 and NaCl. The organic layer was dried over MgSO_4 and the solvent removed at $20^\circ\text{C}/15$ Torr. The diol **3a** was isolated by silica gel column chromatography with 20:1 methylene chloride/ethyl acetate as eluent to afford 974 mg (53%) of a colorless oil: R_f (20:1 methylene chloride/ethyl acetate) 0.21; IR (CCl_4) ν 3520–3280, 2885, 2805, 1690, 1480, 1440, 1345, 1325, 1265, 1215, 1190, 1125, 1090, 1070, 1040, 960 cm^{-1} ; ^1H NMR (CDCl_3 , 200 MHz) δ 2.73 (t, $J = 6.0$ Hz, 1H), 3.40 (s, 3H), 3.55 (s, 1H), AB pattern ($\delta_A = 3.65$, $\delta_B = 3.83$, $J = 9.3$ Hz, 2H), AB pattern ($\delta_A = 3.66$, $\delta_B = 3.94$, $J_1 = 11.5$ Hz, $J_2 = 6.0$ Hz, 2H), 7.25–7.50 (m, 5H); ^{13}C NMR (CDCl_3 , 50 MHz) 59.6 (q), 68.6 (t), 75.6 (s), 78.4 (t), 125.0 (d), 127.6 (d), 128.4 (d), 140.8 (s). Anal. Calcd for $\text{C}_{10}\text{H}_{14}\text{O}_3$ (182.2): C, 65.90; H, 7.76. Found: C, 65.93; H, 8.04.

2',3',5'-Triacetyl-8-methoxyguanosine (5). A mixture composed of 85.0 mg (0.271 mmol) of 8-methoxyguanosine, 152 mg (1.49 mmol) of acetic anhydride, 139 mg (1.37 mmol) of triethylamine, and 4.00 mg (0.032 mmol) of *p*-(dimethylamino)pyridine, suspended in 5 mL of acetonitrile, was stirred at ambient temperature for 1.5 h. After

addition of 1 mL of methanol, the solution was stirred for 5 min, and the solvent was evaporated at $20^\circ\text{C}/15$ Torr. The crude oil crystallized after addition of a small amount of 2-propanol (ca. 2 mL) and was purified first by silica gel column chromatography with 15:1 methylene chloride/methanol as eluent, followed by recrystallization from 2-propanol to afford 74.6 mg (63%) of colorless plates: R_f (15:1 methylene chloride/methanol) 0.51; IR (KBr) ν 3480–3340, 3260, 3130, 2900, 1730, 1670, 1600, 1570, 1500, 1350, 1210, 1070 cm^{-1} ; ^1H NMR ($\text{DMSO}-d_6$, 200 MHz) δ 1.99 (s, 3H), 2.07 (s, 3H), 2.11 (s, 3H), 3.88 (s, 3H), 4.20–4.50 (m, 3H), 5.61 (m, 1H), 5.90 (d, $J = 4.5$ Hz, 1H), 6.09 (m, 1H), 6.45 (s, br, 2H); ^{13}C NMR ($\text{DMSO}-d_6$, 50 MHz) δ 20.2 (q), 20.2 (q), 20.4 (q), 54.8 (q), 63.0 (t), 69.8 (d), 71.2 (d), 79.2 (d), 87.5 (d), 117.1 (s), 120.1 (s), 151.8 (s), 153.7 (s), 155.4 (s), 169.3 (s), 169.4 (s), 170.0 (s). Anal. Calcd for $\text{C}_{17}\text{H}_{21}\text{N}_5\text{O}_9$ (439.4): C, 46.46; H, 4.83; N, 15.94. Found: C, 45.99; H, 4.79; N, 15.66.

General Procedure for the Reaction of Dioxetane 1a with the Acetylated Nucleosides 8–10. Samples of 27.6–50.0 mg (0.150–0.280 mmol) of dioxetane **1a** were dissolved in 1–5 mL of methanol at 0°C , and 1 equiv of the nucleosides **8–10** was added. The reaction mixture was stirred at 0°C until the negative peroxide test (KI/HOAc) indicated the complete consumption of the dioxetane. The solvent was evaporated at $20^\circ\text{C}/15$ Torr, and the crude product mixture was submitted to NMR analysis by using hexamethyldisiloxane as internal standard.

Reaction of 3-(Methoxymethyl)-3-phenyldioxetane (1a) with 2',3',5'-Triacetyladenosine (8). According to the above general procedure, 50.0 mg (0.280 mmol) of dioxetane **1a** was allowed to react with 109 mg (0.280 mmol) of adenosine **8** in 5 mL of methanol for 3 d. NMR analysis of the crude product mixture showed, besides unreacted adenosine **8**, ω -methoxyacetophenone (**3a**).

Reaction of 3-(Methoxymethyl)-3-phenyldioxetane (1a) with 2',3',5'-Triacetylcytidine (9). According to the above general procedure, 50.0 mg (0.280 mmol) of dioxetane **1a** was allowed to react with 102 mg (0.280 mmol) of cytidine **9** in 5 mL of methanol for 30 h. The ^1H and ^{13}C NMR spectra of the crude product mixture showed, besides the unreacted cytidine **9**, the dioxetane fragmentation product ω -methoxyacetophenone (**3a**).

Reaction of 3-(Methoxymethyl)-3-phenyldioxetane (1a) with 3',5'-Diacyl-2'-deoxythymidine (10). According to the above general procedure, 27.6 mg (0.150 mmol) of dioxetane **1a** was allowed to react with 50.0 mg (0.150 mmol) of 2'-deoxythymidine **10** for 36 h. The crude product mixture was submitted to ^1H and ^{13}C NMR spectroscopy which showed, besides unreacted 2'-deoxythymidine **10**, the dioxetane fragmentation product ω -methoxyacetophenone (**3a**).

Reaction of 3-(Bromomethyl)-3-phenyldioxetane (1b) with 3',5'-Diacyl-2'-deoxythymidine (10). Samples of 571 mg (1.75 mmol) of the 2'-deoxythymidine **10** and 400 mg (1.75 mmol) of the dioxetane **1b** were dissolved in 20 mL of methanol at 0°C . The solution was stored at 0°C for 4 d until no dioxetane **1b** could be detected by TLC, and the solvent was then evaporated at $0^\circ\text{C}/15$ Torr. The ^1H and ^{13}C NMR spectra of the crude product showed, besides unreacted 2'-deoxythymidine derivative **10**, a 45:55 mixture of 1-(bromomethyl)-1-methoxy-1-phenylethyl hydroperoxide (**11b**) and ω -bromoacetophenone (**3b**). The hydroperoxide **11b** was too labile for isolation and purification by low-temperature silica gel column chromatography and, hence, was characterized by NMR spectroscopy.

1-(Bromomethyl)-1-methoxy-1-phenylethyl hydroperoxide (11b): ^1H NMR (CDCl_3 , 200 MHz, -20°C) δ AB pattern ($\delta_A = 3.84$, $\delta_B = 3.95$, $J = 10.4$ Hz, 2H), 3.92 (s, 3H), 4.74 (br, s, 2H), 7.30–7.50 (m, 5H); ^{13}C NMR (CDCl_3 , 50 MHz, -20°C) δ 40.3 (t), 54.4 (q), 75.7 (s), 89.9 (t), 125.2 (d), 127.8 (d), 128.5 (d), 141.0 (s). To the above reaction mixture was added 460 mg (1.75 mmol) of triphenylphosphine at 0°C . After the mixture was stirred for 5 min, no peroxide could be detected by KI/HOAc. The solvent was evaporated at $20^\circ\text{C}/15$ Torr, and 217 mg of β -hydroxy ether **12b** was isolated as a colorless oil by silica gel chromatography with 20:1 methylene chloride/methanol as eluent.

1-Bromo-2-methoxy-2-phenylpropan-3-ol (12b): R_f (20:1 methylene chloride/methanol) 0.47; IR (CCl_4) ν 3660–3520, 3520–3260, 3060, 3030, 2940, 2820, 1595, 1490, 1445, 1420, 1240, 1195, 1070, 965 cm^{-1} ; ^1H NMR (CDCl_3 , 200 MHz) δ 1.97 (s, br, 1H), 3.19 (s, 3H), 3.78–4.04 (m, 4H), 7.27–7.48 (m, 5H); ^{13}C NMR (CDCl_3 ,

50 MHz) δ 35.4 (t), 50.9 (q), 65.1 (t), 79.9 (s), 126.8 (d), 128.2 (d), 128.4 (d), 138.5 (s). Anal. Calcd for $C_{10}H_{13}BrO_2$ (245.1): C, 48.99; H, 5.36. Found: C, 48.71; H, 5.35.

Reaction of 2-(Bromomethyl)-2-phenyloxirane (13b) with 3',5'-Diacetyl-2'-deoxythymidine (10). Samples of 84.0 mg (0.400 mmol) of epoxide **13b** and 129 mg (0.400 mmol) of 2'-deoxythymidine **10** were dissolved in 10 mL of methanol and stirred at room temperature for 48 h. After evaporation of the solvent at 20 °C/15 Torr, the crude product mixture was submitted to NMR spectroscopy. Besides unreacted 2'-deoxythymidine **10**, β -hydroxy ether **12b** was observed quantitatively.

3',5'-Diacetyl-3-methyl-2'-deoxythymidine (14). A sample of 150 mg (0.440 mmol) of 2'-deoxythymidine **10** was dissolved in 10 mL of methanol, and the solution was cooled to 0 °C. An ether solution of diazomethane (0.660 mmol, ca. 1.5 equiv) was added, and on warming to ambient temperature, the mixture was stirred for 14 h. The solvent was removed at 20 °C/15 Torr and the crude product mixture submitted to silica gel column chromatography. By eluting with 40:1 methylene chloride/methanol there was obtained 142 mg (91%) of the *N*-methylated 2'-deoxythymidine **14** as a colorless oil: R_f (20:1 methylene chloride/methanol) 0.38; IR (CCl_4) ν 3130, 2960, 2930, 1730, 1690, 1655, 1630, 1455, 1370, 1355, 1285, 1250, 1215, 1180, 1090 cm^{-1} ; 1H NMR ($CDCl_3$, 200 MHz) δ 1.92 (d, $J = 1.2$ Hz, 3H), 2.08 (s, 3H), 2.09 (s, 3H), 2.06–2.20 (m, 1H), 2.45 (ddd, $J_1 = -14.2$ Hz, $J_2 = 5.7$ Hz, $J_3 = 2.2$ Hz, 1H), 3.31 (s, 3H), 4.2–4.4 (m, 3H), 5.19 (td, $J_1 = 6.6$ Hz, $J_2 = 2.4$ Hz, 1H), 6.32 (dd, $J_1 = 8.4$ Hz, $J_2 = 5.7$ Hz, 1H), 7.25 (m, 1H); ^{13}C NMR ($CDCl_3$, 50 MHz) δ 13.4 (q), 20.7 (q), 20.8 (q), 27.8 (q), 37.5 (t), 63.7 (t), 74.0 (d), 81.9 (d), 85.4 (d), 110.4 (s),

132.3 (d), 150.8 (s), 163.3 (s), 170.1 (s), 170.3 (s). Anal. Calcd for $C_{15}H_{20}N_2O_7$ (340.4): C, 52.93; H, 5.93; N, 8.23. Found: C, 52.95; H, 6.07; N, 8.31.

Reaction of 3',5'-Diacetyl-3-methyl-2'-deoxythymidine (14) with 3-(Methoxymethyl)-3-phenyldioxetane (1a). A sample of 10.0 mg (0.281 mmol) of 2'-deoxythymidine derivative **14** was dissolved in 1 mL of methanol at 0 °C, and 5.13 mg (0.282 mmol) of dioxetane **1a** was added. The reaction mixture was stirred for 40 h at 0 °C until a negative peroxide test (KI/HOAc) was seen, and the solvent was removed at 20 °C/15 Torr. The 1H and ^{13}C NMR spectra of the crude reaction mixture showed, besides recovered 2'-deoxythymidine **14**, the dioxetane fragmentation product *o*-methoxyacetophenone (**3a**).

Reaction of 3',5'-Diacetyl-3-methyl-2'-deoxythymidine (14) with 3-(Bromomethyl)-3-phenyldioxetane (1b). To a solution of 10.0 mg (0.281 mmol) of 2'-deoxythymidine **14** in 1 mL of methanol at 0 °C was added 6.43 mg (0.281 mmol) of dioxetane **1b**. The reaction mixture was stirred for 36 h at 0 °C until a negative peroxide test (KI/HOAc) was seen, and the solvent was removed at 20 °C/15 Torr. NMR analysis of the crude product mixture indicated, besides unreacted 2'-deoxythymidine **14**, the dioxetane fragmentation product *o*-bromoacetophenone (**3b**).

Acknowledgment. This work was supported by the Deutsche Forschungsgemeinschaft (SFB 172 Molekulare Mechanismen kanzerogener Primärveränderungen) and the Fonds der Chemischen Industrie.

JA942213S